

SAVE UP TO 70% INSTALLATION TIME

ATLANTIS FLO-VAULT® MODULAR UNDERGROUND TANK SYSTEM

INSTALLATION GUIDE

APPLICATIONS COVERED

- Infiltration Tanks
- Re-use Tanks (Rainwater Harvesting Tank)
- O.S.D (On Site Detention Tanks)

Additional Materials Required

Backfill Materials

- Washed Sand (Technical specifications available upon request)
- Aggregate / Gravel 20mm (Technical specifications available upon request)
- Growing Media, in accordance to local guidelines.

Other Materials

- Duct Tape
- Firestone Butyl Tape or equivalent (For pipe boot connections to liner)
- Stainless Steel Pipe Clamps
- PVC Pipes

Machinery

- Hand Held Compactor
- Excavation Machinery
- Equally distributed load light vehicle (PT-30/50 Terex or similar)

Geosynthetic Materials

- Bidim A29 nonwoven geotextile
- Tensar TX160 geogrid if specified by engineer
- Plastic Liner
 - 1.00mm LLDPE liner
 - 1.5mm HDPE liner
- Liner Protection geotextile
 - Bidim A44 geotextile

Important Design & Installation Considerations

1. CONSTRUCTION OF ATLANTIS FLO-VAULT SYSTEM WITHIN A PROJECT

Carefully plan and coordinate the installation of the Atlantis Flo-Vault system with other work on the project such as grading, excavation works, utilities installation, construction of access roads, site compaction and erosion management. The following documents shall be submitted to the engineer: Geotechnical design report and all relevant design information (elevation plans, site photos, hydrological/hydraulic studies etc.)

2. CONSTRUCTION & SITE TRAFFIC

Keep all construction traffic away from the limits of excavation until the project is completed and final surface materials are in place as approved by engineer or project manager in charge. Provide for a minimum setback of 5 m

- Prevent all non-installation related construction traffic from being around the Atlantis Flo-Vault underground system when work is in progress.
- Ensure adjacent work does not negatively impact the installation of the Atlantis Flo-Vault system.

3. POST CONSTRUCTION SIGNAGE

After installation is finalized install permanent signs that display warnings of maximum loadings allowable over the tank installation. See page 26.

4. APPOINTED CONTRACTOR PERFORMING INSTALLATION

Installation must be performed only by skilled and competent contractors with satisfactory record of performance and quality on underground installations. Contractors must adhere to the manufacturers installation guidelines and engineering specifications. If the plans or drawings conflict with our installation guide, please notify our office.

5 INSTALLATION APPROVAL CONSIDERATIONS

Engineering specifications must provide adequate *Partial Factors of Safety* for creep, static and dynamic loads as per AS4678, AS2566, AS5100 and AS1170. Other factors that must be taken into consideration are geo technical evaluation of the site for ground conditions that are seasonal, telluric and contains soils that is prone to liquefaction.

6. INSTALLATION APPROVAL

Installation approval constitutes acceptance of existing conditions and the chain of responsibility for satisfactory performance. If existing conditions are found unsatisfactory, contact the Specifying Engineer for further advice.

7. SUITABLE SUBSTRATE FOR INSTALLATION

Check that substances that can deteriorate the plastic are not present at excessive concentration. It is highly suggested to carry out a size specific check on this. For OSD, the geomembrane around the system will prevent cross contamination, however an appropriate geomembrane should be chosen.

8. SITE CONTAMINATION

When considering the use of Atlantis Flo-Vault System in contaminated ground one should insure substances that can cause deterioration of plastics are not present at excessive concentration levels.

9. INFLOW WATER QUALITY

All water entering the system must be filtrated, free of gross pollutants, silts, litter, grit, sediments, oils and associated aromatic chemicals that can cause deterioration of the system, as the following chemicals: Benzene and derivatives, Acenaphthene Benzo-perylene, Carbon, Tetrachloride, Heptane, Kerosene Mineral Oil (White), Nitric Acid, Sulphuric Acid and Toluene chemicals are not recommended for polypropylene.

10. GEOTEXTILE REQUIREMENTS

For all applications, the geotextile should be a nonwoven needle punched geotextile.

The recommended geotextile shall satisfy the requirements of TNZ F/7 Specification for Geotextile Strength Class C Filtration Class 1.

11. DISTANCE FROM EXISTING STRUCTURES

Before excavating please check soil types to determine the minimum distance of the excavation from existing structures.

Soil Type	Typical Hydraulic Conductivity (cm/s)	Typical Hydraulic Conductivity (mm/hr)	Modification Factor (U)	Minimum Setback Distances from structures and boundaries (m)
Sand	5.00E-03	180	0.5	1.0
Sandy Clay	1.00E-03 - 5.00E-03	36 - 180	1.0	2.0
Weathered or Fractured Rock	1.00E-04 - 1.00E-03	3.6 - 36	-	2.0
Medium Clay	1.00E-04 - 1.00E-03	3.6 - 36	2.0	4.0
Heavy Clay	1.00E-06 - 1.00E-04	0.036 - 3.6	2.0	5.0

12. ATLANTIS FLO-VAULT IS MANUFACTURED FROM 100% RECYCLED MATERIALS

Atlantis Flo-Vault is manufactured from 85% recycled polypropylene and 15% proprietary selected materials.

13. EXCAVATION, BACKFILL & TANK LOADING REQUIREMENTS

The excavation for Atlantis tank modules must consist of the following parameters:

EXCAVATION DEPTH = Base Fill + Tank Height + Specified Backfill Height

EXCAVATION AREA = Tank Footprint + Minimum Side Backfill

ATLANTIS FLO-VAULT® MINIMUM TOP COVER & BACKFILL REQUIREMENTS

FILL	PEDESTRIAN TRAFFIC	VEHICLE TRAFFIC
BASE FILL	100mm	100mm
SIDE BACKFILL*	300 - 500mm	300 - 500mm
BACKFILL HEIGHT**	300	600

***SIDE BACKFILL**

For installations that have limited footprint available, 100mm can be applied if approved by specifying engineer. Narrow side backfill must be compacted to 95%. For installations into reactive soils or clay a minimum of 500mm side backfill is required.

IF BACKFILL EXCEEDS 2 METERS CONTACT ATLANTIS TECHNICAL DEPARTMENT.

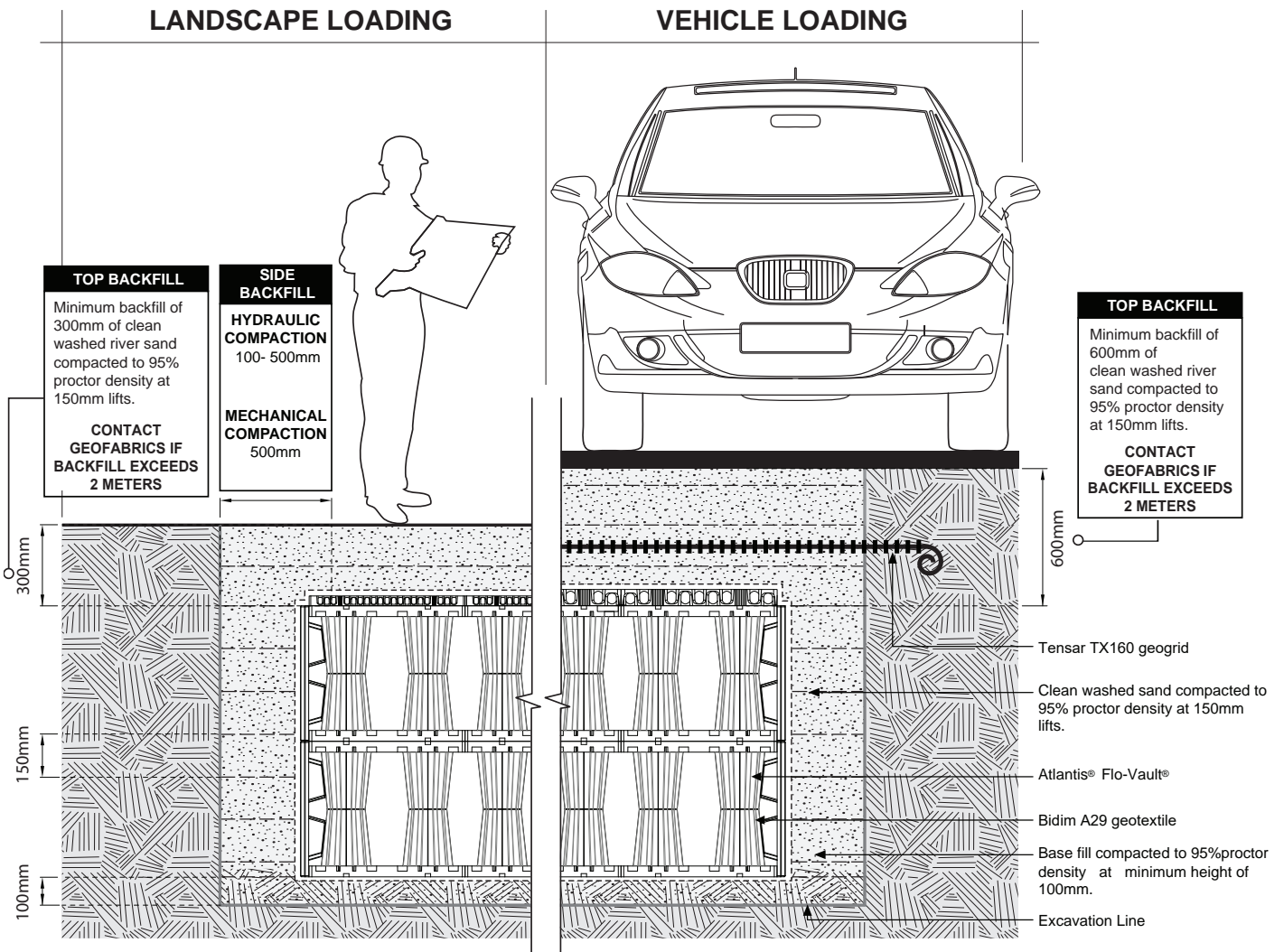

14. SUITABLE STRUCTURAL BACKFILL

S = Coarse Washed Sand with less than 5% fines passing 75 micron sieve

A = Aggregate of angular material up to 19mm

	Infiltration	Rain Harvesting	Detention
Base Backfill	S	S	S
	A	A	A
Side Backfill	S	S	S
	-	A	A
Top Backfill	S	S	S
	-	A	A

Note: Technical specifications available upon request

15. INSTALLATION OF POLES, DEEP FOOTINGS, SERVICES NEAR TANK INSTALLATION

Any excavation of Light Poles, Closed-circuit Television (CCTV) Poles or any similar structure above or below ground must be kept 5 meters away from the excavation perimeter. Ensure piling machinery is kept 3 meters away from the excavation perimeter. The zone of influence of any adjacent excavation could extend up to approximately 2 to 3 times the depth of the excavation producing ground movements. These recommendations must be reviewed and approved by a suitable qualified engineer.

16. EARTHWORKS NEAR ATLANTIS UNDERGROUND TANKS

When excavating adjacent to the Atlantis Flo-Vault tank there is a risk of destabilising the pre-excavation ground stress. This ground stress is established soon after the installation of the Atlantis tank and keeps the tank in force equilibrium. Proposed excavations in close proximity are therefore not permitted if there is risk of structural failure or potential collapse of the Atlantis Flo-Vault tank.

It is the owners responsibility to ensure all parties proposing excavations near the Atlantis Flo-Vault tank, whether external to or within the owners property boundaries, have been granted approval from qualified structural and geotechnical engineers. This approval should be in the form of a certificate by a competent structural/geotechnical engineer with relevant engineering authority based on results of an appropriate geotechnical or structural investigation.

IMPORTANT: THE GROUND STRESS SURROUNDING THE ATLANTIS FLO-VAULT TANK MUST BE PERSEVERED TO ENSURE THE STRUCTURAL INTEGRITY OF THE TANK SYSTEM.

Infiltration Tank (Absorption)

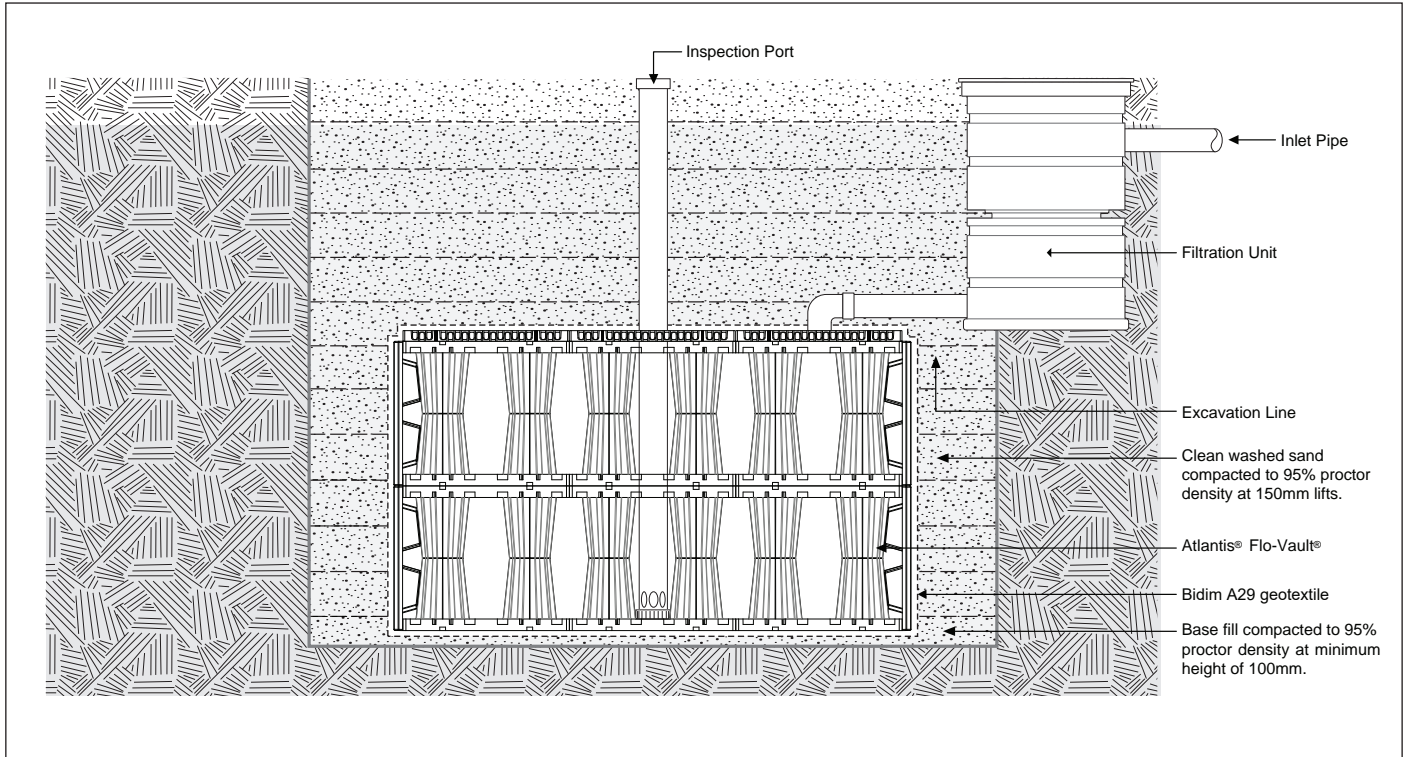

O.S.D Tank (On-Site Detention)

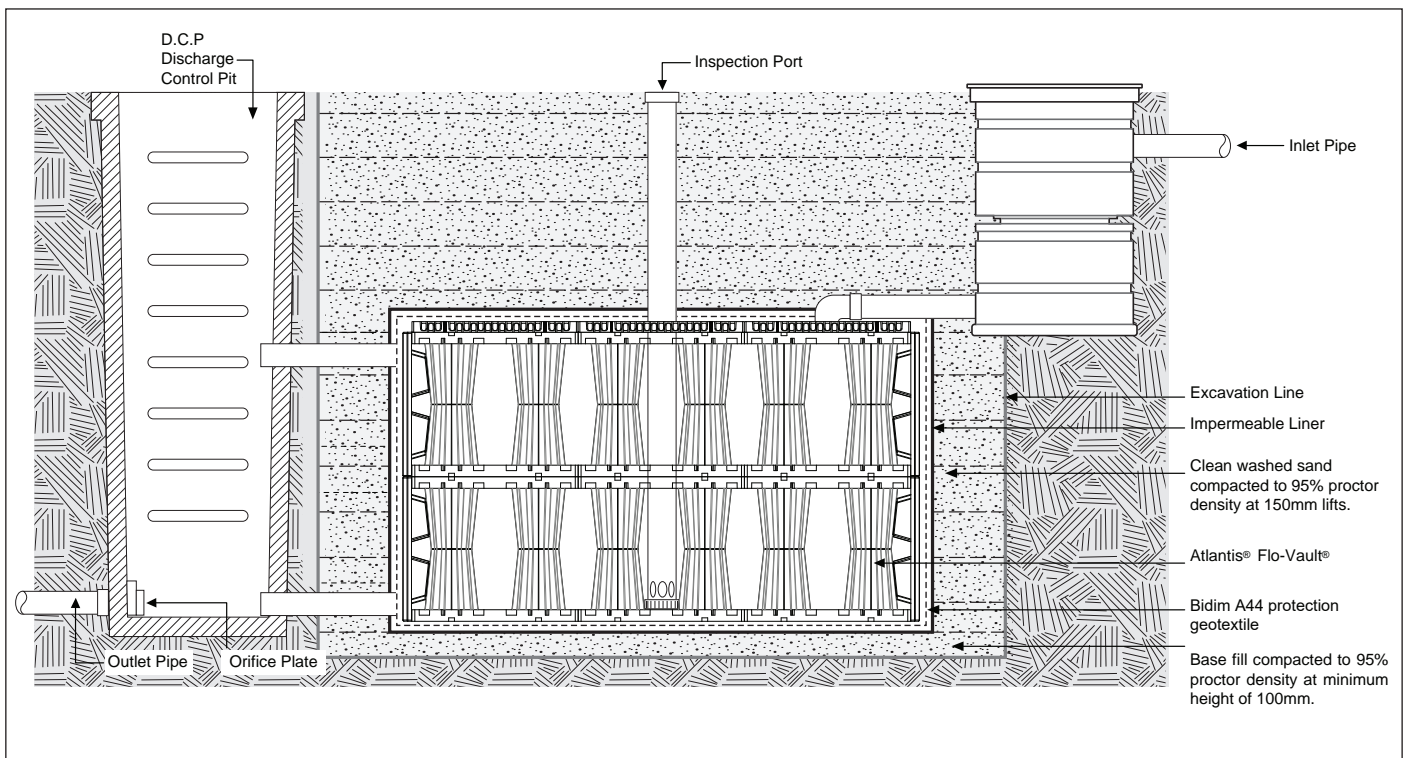

Rainwater Harvesting (Sealed Version)

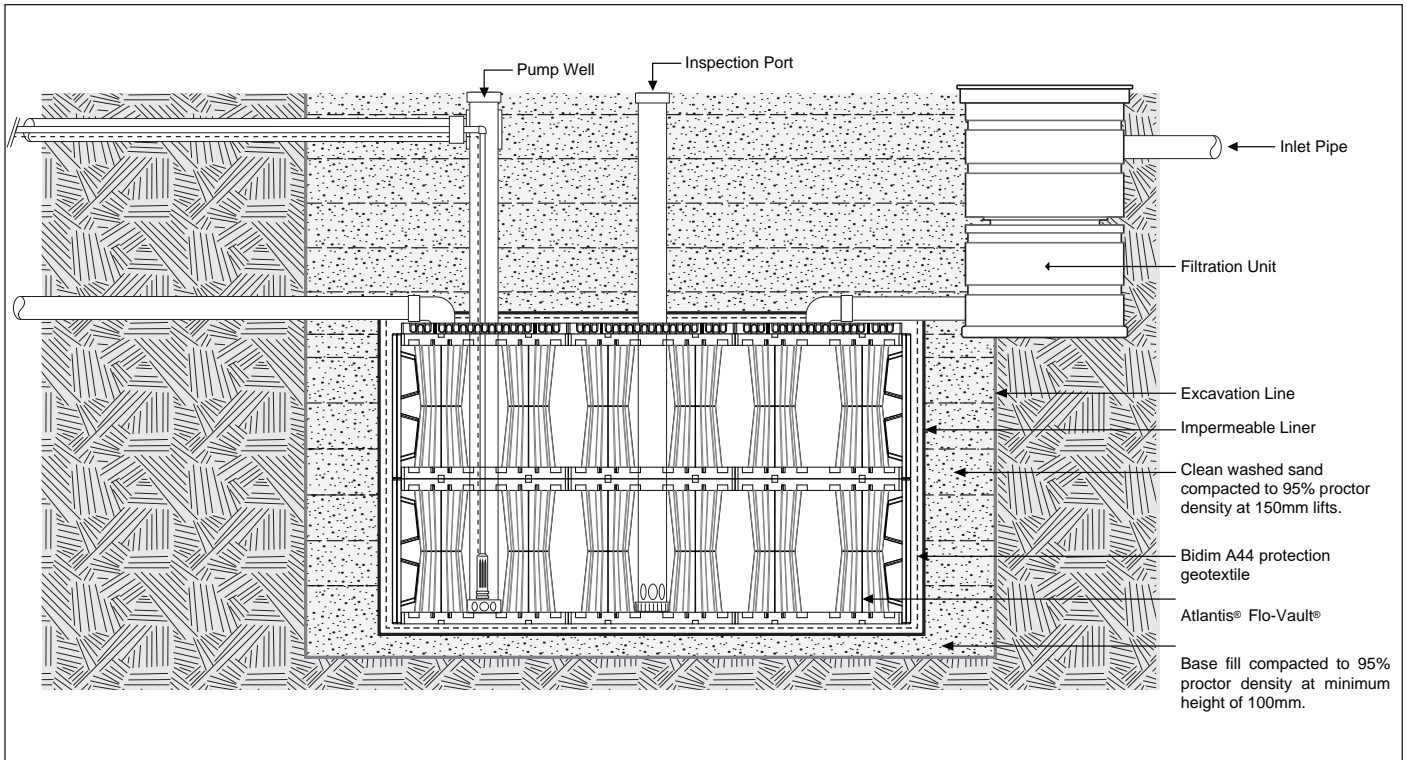

Rainwater Harvesting (Sand Lined Version)

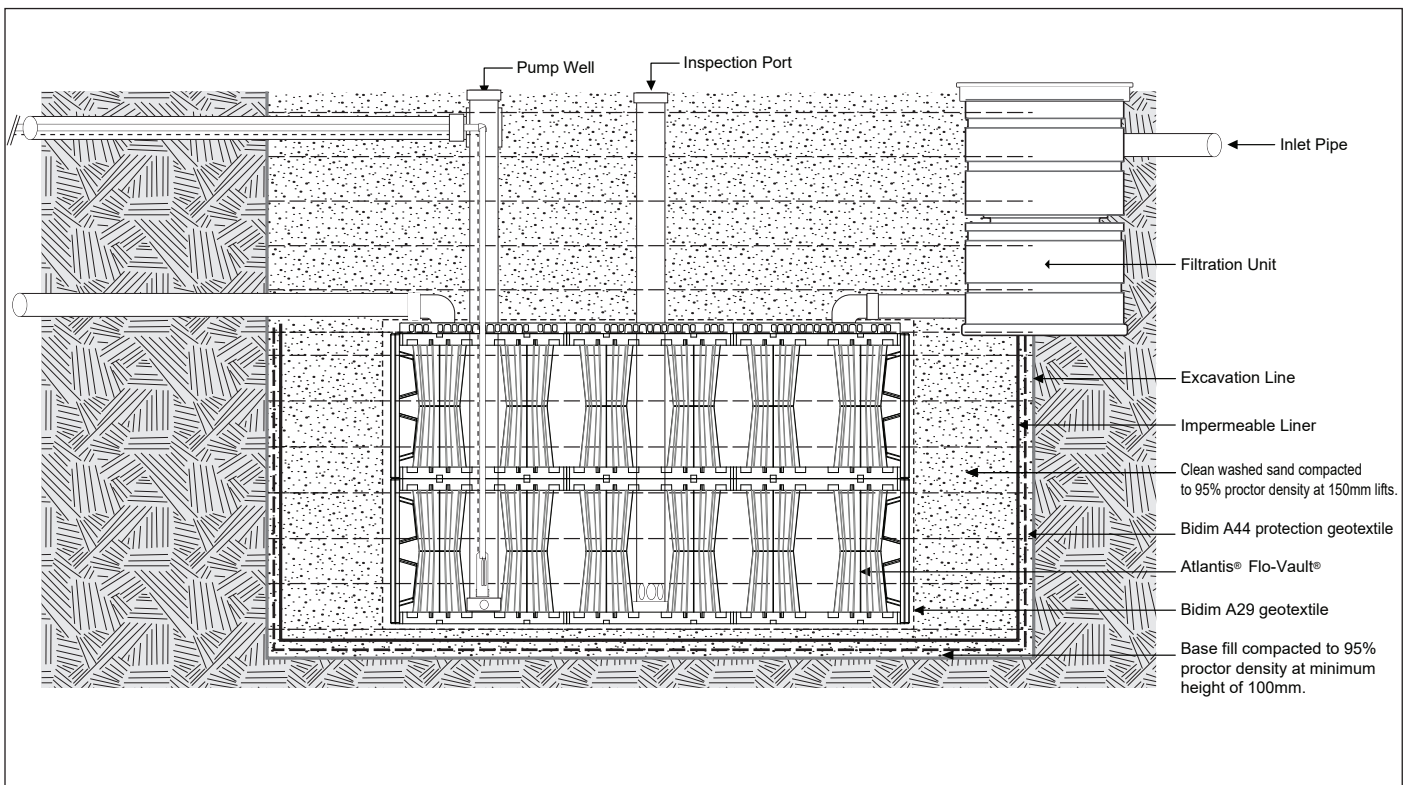

STEP 1 - EXCAVATE



EXCAVATION FOOTPRINT

(Tank Length) + (Tank Width) + (Minimum Side Backfill)
= (EXCAVATION FOOTPRINT)

EXCAVATION DEPTH

(Tank Depth) + (Minimum Top Cover) + (Base Layer)
= (EXCAVATION DEPTH)

Prepare excavation as per geotechnical engineer's specifications and/or as shown on engineering drawings. The excavation must be level before the base fill can be applied.

Examine prepared excavation and conditions for level smoothness and compaction. Correct unsatisfactory conditions before commencement of base preparation layer.

Check for the presence of soft or muddy soils. Insure the presence of a high ground water table is at least 1m feet below the bottom of the Atlantis Tank structure at all times.

Ground foundations with a clay profile are considered non-standard conditions. The design must be approved by a geotechnical engineer.

HEAVY RAINFALL EVENTS: If a high ground water table is likely to rise during a heavy rainfall event then adequate sub surface drainage is required to alleviate hydrostatic pressure on the tank structure.

STEP 2: PREPARE BASE



Base Layer Installation

Apply a level base of 100mm - 200mm of smooth clean washed sand, free from lumps and debris or any other sharp materials and compact to 95% modified proctor density.

Structural fill material of either washed sand or gravel of 19mm in size is acceptable for base materials. Technical specifications are available upon request.

The foundation should achieve a CBR of 3-5% and be checked by the authorised engineer.

STEP 3: PLACE GEOTEXTILE TO WRAP TANK



Lay the geotextile into the excavation. Use sandbags or heavy objects to temporarily secure the geotextile at the top of the excavation to prevent the fabric from falling into the excavation.

Over lap the edges by a minimum of 300mm. Ensure 300mm of geotextile is available on the ends to wrap over the tank system.

RAINWATER & O.S.D TANKS ONLY

STEP 3 B: LAYING THE IMPERMEABLE PLASTIC LINER ALONG THE BASE AND UP THE SIDES



Lay impermeable liner into the excavation and spread out evenly. Ensure the Impermeable liner is centred into position and that the minimum allowable overlap of 1m is available on all edges of the tank system to fold over the top of the tank system.

Take care not to tear or puncture the liner. Overlapping edges and joints should be welded by an experienced polyplastic welder. Tank configurations should have as few welded joints as possible.

STEP 3 C: LAYING PROTECTIVE LAYER OF GEOTEXTILE

Lay geotextile fabric into the excavation as a protective layer between the impermeable liner and the Atlantis Flo-Vault® modules.

Secure overlapping edges with duct tape.



STEP 4: INSTALL TANK MODULES

IMPORTANT: Before assembly of the tank structure check plans to evaluate positions of MAINTENANCE PORTS and INSPECTIONS PORTS and take note of their position. Where these ports are to be installed the Flo-Vault® modules must have the centre cut out with a 150mm holesaw to allow the pipe to be inserted through the modules. Place these cut modules aside and install them into their correct location during the assembly of the main tank structure. The base of the module located at the bottom of the tank does not require the centre cut out.

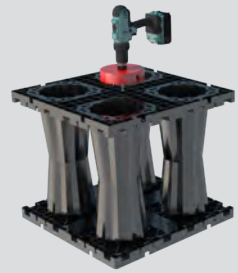

The boundaries of the tank is best carried out by surveyors to ensure a straight installation. Commence the tank assembly in the area where critical pipe connections need to be made. Place the modules into the corner of the excavation following the string lines as a guide.

STRING LINES FACILITATE INSTALLATION OF BASE LAYER



INSTALLING FLO-CELL® CAPPING LAYING OVER TANK MODULES



INSTALLING TANK MODULES



STEP 1

Place the Flo-Vault® half into position.

STEP 2

Place the other half and clip into place.

STEP 3

Place adjacent half into place.

STEP 4

When the first layer is complete install the joining clips.

STEP 5

Commence the assembly of the second layer.

STEP 6

Continue assembly of second layer.

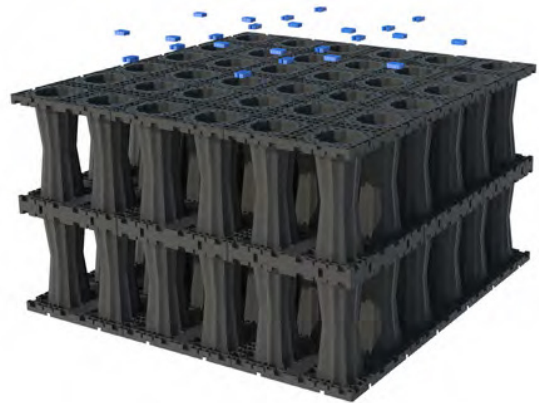
STEP 7

Install connecting clips after layer is complete.

STEP 8

When main tank structure is assembled install the side plates by clicking them into place.

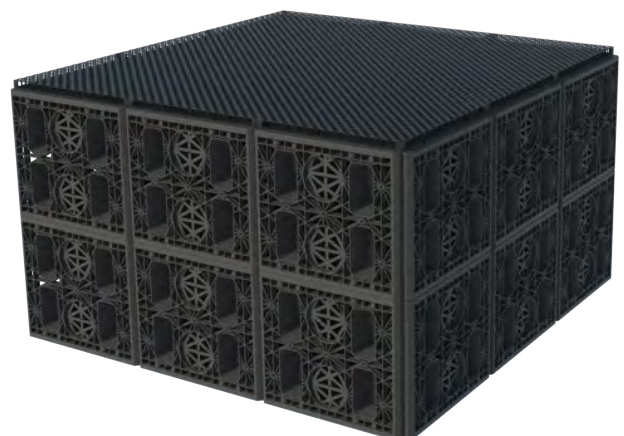
STEP 9

Install a layer of Atlantis Flo-Cell® over the tank modules. Either 30mm or 50mm Flo-Cell® can be used. The Flo-Cell® can be cut to allow maintenance ports and inspection ports.

STEP 5: INSTALL MAINTENANCE PORTS

INSPECTION • MAINTENANCE • VENTILATION

For large tank systems in the order of over 10,000L and over it is recommended to use multiple maintenance ports, as an estimate, one for every 25,000L of volume.

Typically made from PVC pipe, these provide vertical access into the system. They should be long enough to sit on the bottom of the Flo-Vault® module, rising to the finished surface where they are capped.

For an effective and on-going underground water system a good maintenance design plan is needed.

Atlantis recommends two tools, which can help achieve a good long-term maintenance system. Ventilation ports & maintenance/inspection ports.

1. Ventilation ports can be installed with a single pipe protruding from different equally spaced sections of the tank. These pipes should be placed in all underground tanks, whether for infiltration, detention or retention. A perforated pipe with a diameter of 150mm. This is drilled into the center of the module. These ports allow the system to breathe and prevents a vacuum from forming when large quantities of water is withdrawn from the tanks.

2. Maintenance ports or inspection ports are used as access openings for flushing the system or for cameras/visual aide instruments respectively. They are important for flushing (with vacuum trucks) and removing blockages due to sedimentation from failed filters. These are highly recommended for large and small tank systems.

NOTE: ENSURE INSPECTION PIPES ARE CAPPED TO PREVENT DEBRIS ENTERING THE SYSTEM.

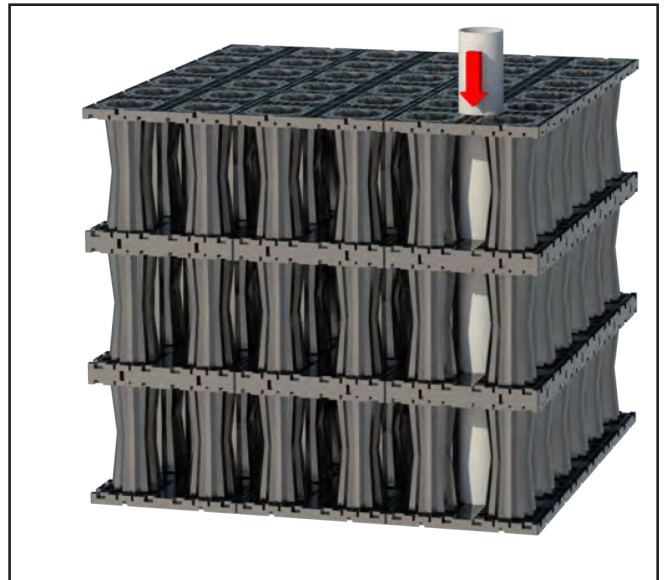

STEP 6 A: WRAP TANK IN GEOTEXTILE



Wrap Geotextile placed in Step 3, over the Flo-Vault® modules.

Seal all the seams and joins of the geotextile using duct tape. There should be a minimum of 300mm overlap at the joins and seams.

Sealing the system insures that backfill materials are kept out of the system.

Put utility tape on all corners of the tank to determine sub-surface location in the future.

RAINWATER & O.S.D TANKS ONLY

STEP 6 B: SEAL SYSTEM WITH LINER



Constructed tank is wrapped in geotextile.



Liner is pulled up over the constructed tank.

STEP 7 A: Connect Inlet / Outlet Pipes

IMPORTANT: All water entering the Atlantis Flo-Vault system must be filtered by an approved filtration device. Raw stormwater containing gross pollutants and heavy sediments must be kept out of the Atlantis Flo-Vault system.

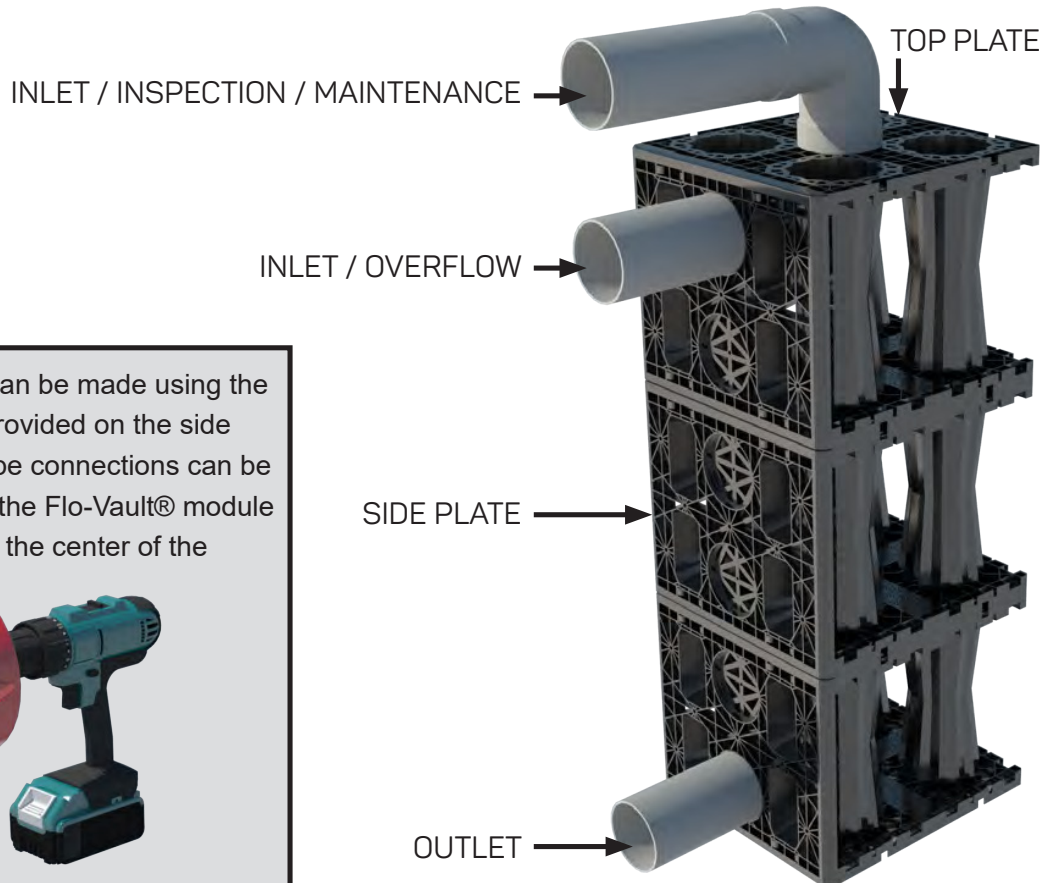

Pipe connections can be made using the designated ports provided on the side plate. Additional pipe connections can be made to the top of the Flo-Vault® module by cutting a hole in the center of the module.



The hole can be cut using a 150mm holesaw. The ports are for 150mm pipes.

Wherever a pipe must pass through the geotextile, cut an “X” in the geotextile, pull the four flaps back over the pipe. Use duct tape to seal around the pipe, then attach stainless steel clamp to securely fasten the connection.



NOTE: Flo-Vault® tank systems should not be activated or brought on-line until construction is completed and the site is stabilized. This will prevent construction debris and heavy sediments from contaminating the system.

STEP 8: Backfill Sides

NOTE: Compact back fill layers in 150mm lifts.

Side backfill must consist of clean washed sand free from silt and clays. Backfill materials containing clay should NEVER be used.

Compact side fill in 150mm lifts and compact to 95% proctor density. Each compacted lift must be constructed on all sides of the tank structure before the next lift can be constructed. Use a powered mechanical compactor to compact the lifts.



When using a mechanical compactor cover the side of the tank system with a sheet of plywood to protect the fabric and tank modules from damage. Move the plywood sheet as the compactor moves.

Side backfill can range in width from 200mm to 500mm for standard applications. If you have a minimal footprint and have to limit your side fill please contact our technical department for directions.

For installations into reactive soils or clay a minimum of 500mm side backfill is required.

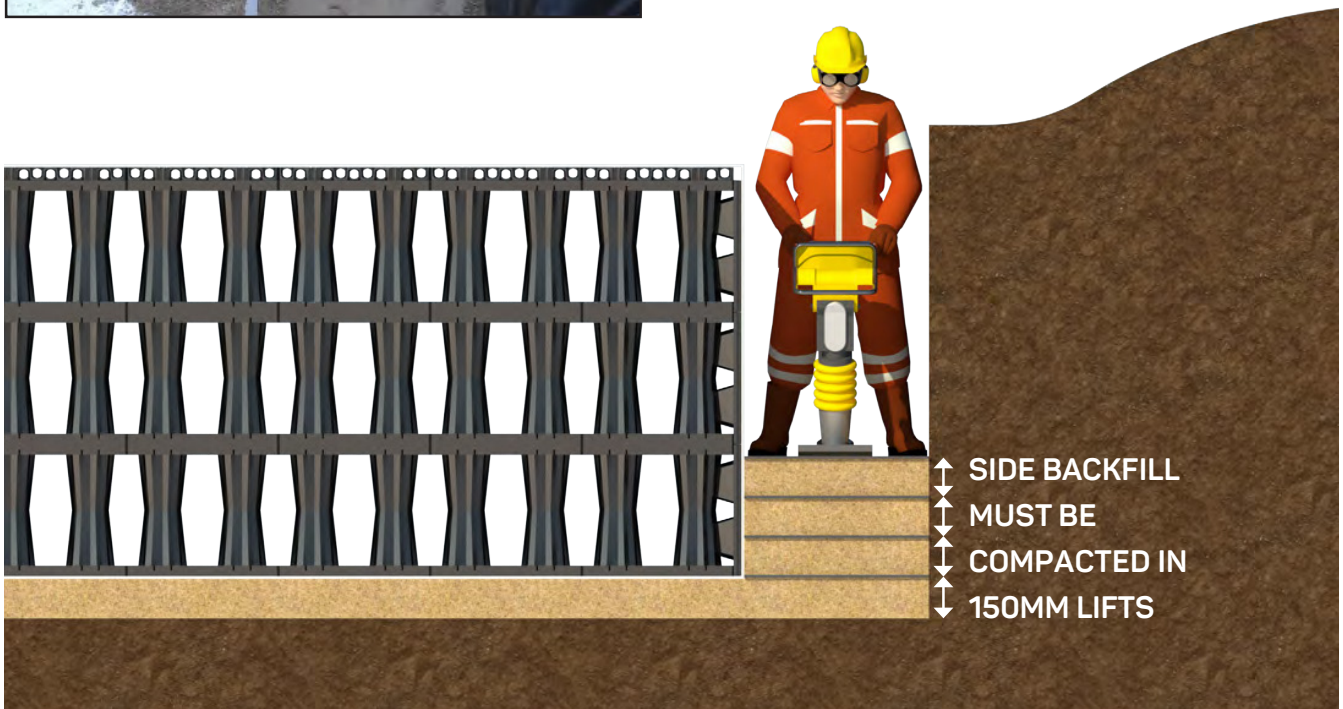

STEP 9: Backfill Top

MINIMUM TOP COVER REQUIRED

Pedestrian Traffic 300-500mm

Vehicular Traffic 600-1000mm including any road base and surfacing materials

MINIMUM BACKFILL UNDER CONCRETE SLAB for lightweight traffic load: A minimum of 100mm of top backfill can be applied when specified under a 150mm reinforced concrete slab. Seek approval from a structural engineer.

MAXIMUM BACKFILL: If backfill exceeds 2 meters contact Atlantis Technical Department.



When placing backfill materials be careful to avoid damage or displacement of the tanks and geotextile fabric. Excavator equipment shall remain clear of the excavation. Material shall not be dropped vertically on the tank from a distance greater than one-foot.

Exercise care when placing the first 150mm lift on the tank structure. The next 150mm lift may be placed using lightweight vehicle with tracks. Place at least 500mm of material and blade down to 300mm, where required, then compact to 95%.



NOTE: NO VEHICLES are to drive directly over the tank modules unless the initial 150mm compacted layer of backfill material has been laid.



* For large scale projects, spread the backfill material with a low ground pressure skid steer loader (i.e. Posi Track)

STEP 10: Place Geogrid (optional)



Geogrid is required for load-bearing applications such as systems placed below parking lots.

Geogrid should be Tensar TX160 and should extend 1m beyond the excavation footprint.

Overlap all edges by 500mm or as recommended by manufacturer or engineer. Continue backfilling to recommended levels in 150-300mm lifts with compaction to 95%.

STEP 11 - Site Final Cleaning

Perform final cleaning of work and remove all excess material, debris and equipment. Repair any damage to adjacent materials and surfaces resulting from installation of this work.

STEP 12 - Surface Materials

Place surfacing materials such as ground covers, shrubs or paving materials over the structure with care to avoid displacement of cover fill and damage to surrounding areas.

STEP 13 - Erect Perimeter Fencing



Following completion of the work, mark the perimeter of the system footprint and place temporary fencing to restrict heavy traffic or impact above the system until construction of the site is complete.

STEP 14 - Permanent Perimeter

When necessary install permanent signs that display warnings of maximum loads allowable over the tank installation. Permanent bollards (traffic post) can also be installed to prevent any traffic from entering the tank location.

STEP 15 - System Commissioning / Bringing the System Online

Direct all site stormwater runoff away from the installation area during construction. The installation area shall not receive any run off. To maintain the area provide temporary erosion control devices and landscaping that minimizes the entry of silts and clay into the infiltration installation area.

Step 7 B: Installation of Pipe Boot to Liner

Liner Preparation

When installing pipe boots it is important that the liner is flat against the modules without creases or wrinkles and the surface is clean and dry. The liner should now be secured against the crates in its final location.

Determine Position of Pipe and Cut Out Hole In Liner

With the pipe in place, carefully cut the liner around the pipe and remove the section of liner.

Prepare Final Position of Pipe

Slide the pipe boot over the pipe, then position pipe at its final location and fix into place with compacted backfill. It is important that the pipe does not move after the pipe boot is bonded to the liner as this movement may break the seal or damage the pipe boot causing failure.

Mark Flange Position

Slide the flange of the pipe boot against the liner, then mark the liner around the flange with a felt tip marker.

Primer Application

Slide the pipe boot back along the pipe out of the way. Then, with the application pad supplied, apply a good thick bead of primer 100mm wide around the inside of the line. Overlap the line by about 10mm. Even out the primer with the pad as much as possible so there is a uniform thickness. Allow the primer to flash off till touch dry. This should be less than 10 minutes depending on the ambient temperature.

Position Flange

When the primer is touch dry slide the pipe boot back into place lining up the edge with the primer. Carefully remove the backing paper from one edge of the flange then push the flange against the primer making sure that there are no wrinkles in the liner or flange.

Install Flange

Tightly rub the back of the flange making sure that all of the flange is bonded to the liner. It may be a good idea to install a thin sheet of plywood or similar substance between the crates and the liner to give a firm backing. Repeat this process for the other 3 sides of the pipe boot flange always making sure that there are no wrinkles or folds in the liner or pipe boot flange. Give the flange a good firm rub making sure that there are no bubbles in the bond and that the flange is firmly bonded to the liner. Remove the plywood.

Apply Sealant to Flange

With the tube of sealant supplied, apply a bead of sealant around the outside of the flange about 15mm wide.

Sealing the Pipe Boot to the Pipe

Put a bead of sealant between the pipe boot and the pipe then apply a stainless steel pipe band around the pipe boot and pipe.

Wrap Protective Layer of Duct Tape Around Pipe Clamp

To protect the pipe boot from the sharp edges of the pipe clamp it is a good idea to run a couple of layers of duct tape around the pipe boot prior to installing the pipe clamp.

Self Adhesive Pipe Boot Instructions page

Materials needed



1. Clean the area where the boot is to be installed



2. Trace the edge of the boot onto the tank liner



3. Cut the opening for the pipe



4. Prepare the area of the boot flange with a polypropylene glue



5. The area is ready when the surface is dry to the touch



6. Peel the back corner of the flange to expose the sticky side



7. Mount the boot liner starting from the corner.



8. Insert the pipe and push all the way against the tank



9. Apply the sealant between the liner and the PVC pipe.



10. Move the clamp over and around the boot and tighten

		YES	NO
8.	<p>Pre-treatment/filtration system:</p> <p><input type="checkbox"/> Atlantis Large / Small Filter</p> <p><input type="checkbox"/> Gross Pollutant Trap (GPT)</p> <p><input type="checkbox"/> Biofiltration</p> <p><input type="checkbox"/> Other: _____</p> <p>If NO: The end-user is responsible for the performance of the tanks if there is not a pre-filtration system installed/specified.</p> <p>Note: Sediments, debris and contaminants must be kept out of the system.</p>	<input type="checkbox"/>	<input type="checkbox"/>
9.	<p>Backfill material specified?</p> <p><input type="checkbox"/> Washed sand (less than 5% fines passing 75 micron sieve)</p> <p><input type="checkbox"/> Aggregate of angular material (up to 19mm) Other:</p> <p><input type="checkbox"/> (Material graded to AS 1141) _____</p> <p>If NO: Please seek approval from a geotechnical / structural engineer as to what backfill should be used.</p>	<input type="checkbox"/>	<input type="checkbox"/>
10.	Is the strength capacity of the tank greater than the loads applied on it?	<input type="checkbox"/>	<input type="checkbox"/>
11.	Project was consulted upon and approved by qualified engineers	<input type="checkbox"/>	<input type="checkbox"/>

Company: _____ Date: _____

Designer: _____ Signature: _____

INSTALLATION CHECKLIST

Atlantis system specified:

 Infiltration

 Harvesting (Reuse)

*Impermeable liner required
Always include section 4*

 On Site Detention (OSD)

*Impermeable liner required
Always include section 4*

YES	NO
-----	----

Does the P.O./ Batch Number match the designed load specified by the authorized engineer?

<input type="checkbox"/>	<input type="checkbox"/>
--------------------------	--------------------------

1. EXCAVATION

Note: Please ensure a temporary perimeter fence is erected before excavation.

YES	NO
-----	----

a.	Is the base compacted and leveled? <i>If NO: Correct unsatisfactory conditions before commencement of base preparation layer.</i>	<input type="checkbox"/>	<input type="checkbox"/>
d.	Are contaminated/acid soils and/or filling present? Is the site a landfill? <i>If YES: Design must be approved by an authorised qualified engineer</i>	<input type="checkbox"/>	<input type="checkbox"/>
c.	Are clay/soft/muddy soils and/or high water table present? <i>If YES: Design must be approved by an authorised structural engineer</i>	<input type="checkbox"/>	<input type="checkbox"/>

2. GROUND FOUNDATION - BASE PREPARATION

YES	NO
-----	----

a.	Does the foundation of the excavation have a minimum CBR of 3-5% in accordance with AS 1289.6.1.1? <i>If NO: Design must be approved by an authorised structural engineer</i>	<input type="checkbox"/>	<input type="checkbox"/>
b.	Is the base layer minimum meeting authorised engineer's depth requirements?	<input type="checkbox"/>	<input type="checkbox"/>
c.	Is the base well compacted according to AS 1289.5 and the site graded?	<input type="checkbox"/>	<input type="checkbox"/>

3. GEOTEXTILE USE

YES	NO
-----	----

a.	Is your geotextile hydrophilic? <i>If NO: Ensure the geotextile is hydrophilic</i>	<input type="checkbox"/>	<input type="checkbox"/>
b.	Is there enough overlap available to fold over the top of the tank? <i>If NO: Ensure an overlap by a minimum of 300mm</i>	<input type="checkbox"/>	<input type="checkbox"/>

4. OSD & REUSE INSTALLATION

YES	NO
-----	----

a.	Is there enough overlap for the impermeable liner? <i>If NO: Ensure overlap is available to fold over the top of the tank. Minimum overlap of 1m.</i>	<input type="checkbox"/>	<input type="checkbox"/>
b.	Is there a geotextile layer to protect the liner? <i>If NO: Ensure a geotextile/sand protection layer</i> Note: Please consider the use of an extra strip of geotextile on the corners to protect the liner.	<input type="checkbox"/>	<input type="checkbox"/>

5. INSTALLING ATLANTIS MODULES

YES	NO
-----	----

a.	Are string lines around the boundaries to ensure straight lines <i>If NO: Ensure the tanks are aligned according to original design</i> Note: Best practices recommend that boundaries of the tank should be carried out by surveyors to ensure a straight installation.	<input type="checkbox"/>	<input type="checkbox"/>
b.	Are the modules stacked firmly against each other? <i>If NO: Gaps should not be greater than 5mm.</i>	<input type="checkbox"/>	<input type="checkbox"/>

INSTALLATION CHECKLIST (Continued)

6. INSTALLING MAINTENANCE PORTS

		YES	NO
a.	Inspection/Vent/Flushing Ports If NO: Atlantis tanks must be vented to prevent vacuum effect and may require specific maintenance according to the authorised engineer	<input type="checkbox"/>	<input type="checkbox"/>

7. BACKFILLS

		YES	NO
a.	Backfill material: Either Coarse washed sand with less than 5% fines passing 75micron sieve or Aggregate of angular material up to 19mm or Other granular material graded to AS 1141? If NO: Any other backfill material must be approved by the authorised engineer Note: Backfill materials containing clay should never be used	<input type="checkbox"/>	<input type="checkbox"/>
b.	Backfill sides between 200-500mm? If YES: Compact according to AS 1289.5 If NO: Design must be approved by a structural engineer. Note: When backfilling and compacting, make sure that you do not pinch the liner or rub the compactor against the liner. Protect it with a plywood sheet 20mm thick	<input type="checkbox"/>	<input type="checkbox"/>
c.	Is the top backfill meeting Australian Standards (or local standards) minimum cover requirements and not exceeding 1600mm ? If YES: Compact according to AS 1289.5 If NO: Structural engineers' approval needed. Note: Ensure an equally distributed load light vehicle (i.e. Posi Track) is used to spread and level top backfill	<input type="checkbox"/>	<input type="checkbox"/>
d.	Placing and handling the backfill material: Is the backfill material placed alongside the excavation line around the tank?	<input type="checkbox"/>	<input type="checkbox"/>

8. GEOGRID (Optional)

		YES	NO
	If YES: Ensure a minimum Overlap of 1m Note: Tensar TX160 to be used	<input type="checkbox"/>	<input type="checkbox"/>

9. PIPING

		YES	NO
	Are pipes no greater than 225mm? Inlet: _____ mm Outlet: _____ mm Overflow: _____ mm Other: _____ mm	<input type="checkbox"/>	<input type="checkbox"/>
If YES: Installed according to manufacturers installation guidelines If NO: Ensure pipes greater than 225mm do not penetrate the Tank structure. Note: Overflow according to AS3500.1			

INSTALLATION CHECKLIST (Continued)

10. PROJECT DOCUMENTS

	YES	NO
Maintenance manual provided to the end user?	<input type="checkbox"/>	<input type="checkbox"/>
Handover Document provided to the end user?	<input type="checkbox"/>	<input type="checkbox"/>

11. SITE FINAL CLEANING

	YES	NO
Has cleaning been arranged?	<input type="checkbox"/>	<input type="checkbox"/>

12. PERMANENT PERIMETER

	YES	NO
a. Did you install signage to prevent any traffic from entering the location?	<input type="checkbox"/>	<input type="checkbox"/>
If NO: Ensure a signage is present		

COMMENTS (For quality and training purposes)

	YES	NO
After the excavation: _____	<input type="checkbox"/>	<input type="checkbox"/>
Size / cross section / design matches the site		
Other: _____		

Company: _____ Date: _____

Designer: _____ Signature: _____

Note: Atlantis products are manufactured by independent factories from high quality recycled materials, carefully selected and under strict quality control procedures. The strength could vary slightly due to raw material, country of manufacture, manufacturing process and external conditions.

END USER CHECKLIST

NOTE: The tank is solely used for its purpose to temporarily detain or permanently store potable or treated stormwater

MAINTENANCE GUIDANCE OF PRE-TREATMENT/FILTRATION SYSTEMS

1. Monthly/after significant storm events	
<i>a. No clogging at inlet/outlet structures/trash racks</i>	<input type="checkbox"/>
<i>b. Clean when there is excessive sediment build up in the pre-treatment device</i>	<input type="checkbox"/>
<i>c. Inspect, lubricate and conduct routine test to check reliability of pump(s)</i>	<input type="checkbox"/>
<i>d. Check condition and conduct function test of all pump starters and their controls including level control systems</i>	<input type="checkbox"/>
<i>e. No obstruction of maintenance access/openings</i>	<input type="checkbox"/>
<i>f. Access into the tank system is secure (out of bounds to public and unauthorised personnel)</i>	<input type="checkbox"/>
2. Yearly as required	
<i>g. De-silting of the tank has been carried out, trash screens have been cleaned</i>	<input type="checkbox"/>
<i>h. Inspect, service, replace, lubricate and test performance of pump(s)</i>	<input type="checkbox"/>
<i>i. Check condition and conduct function test of all pump starters and controls including level control systems.</i>	<input type="checkbox"/>
<i>j. Replace faulty and worn out parts if required.</i>	<input type="checkbox"/>

INSTALL PERMANENT SIGNAGE

Signage Should Read:

CAUTION:

UNDERGROUND STORMWATER TANK BELOW *Underlining maximum vehicle loads*

